

CAD FILE:

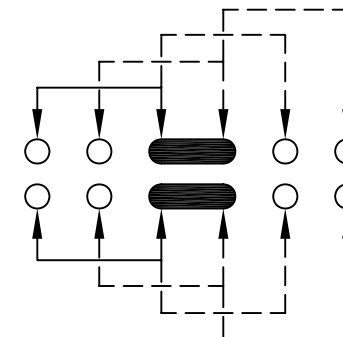

SCHEMATIC (SHORTING)

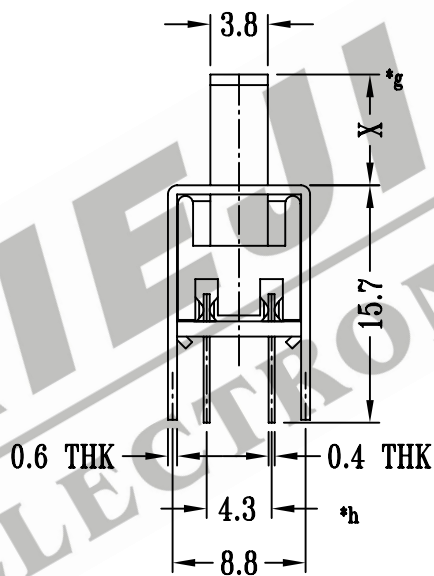
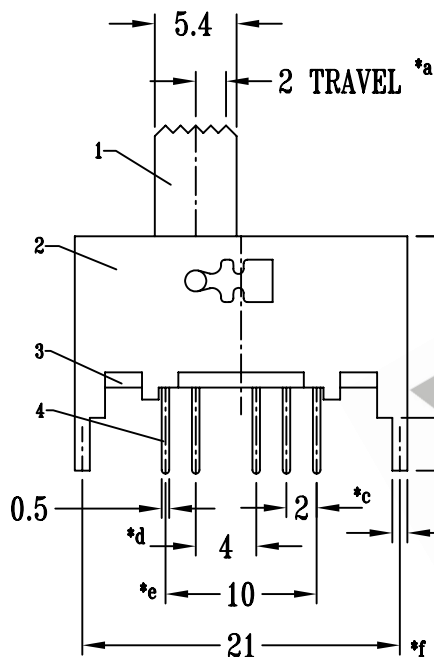
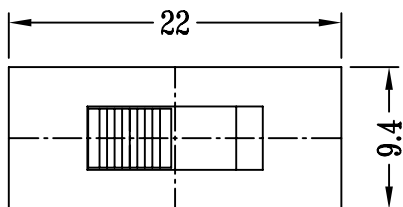
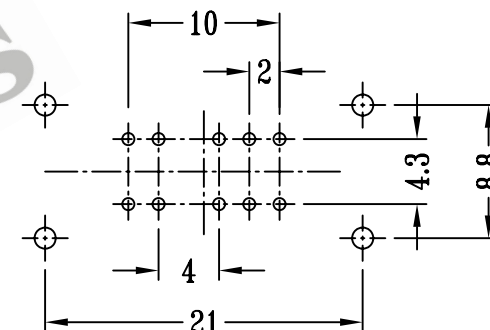

P.C.B LAYOUT

注:带"*"表示关键尺寸(8个)

NO.	PARTS	MATERIALS	Q'TY	FINISH	TOLERANCE UNLESS SPECIFIED	SHENZHEN XIEJIA ELECTRONICS CO.,LTD.			
8						TITLE : VERTICAL SLIDE SWITCH			
7	STEEL BALL	STEEL	2	NATURAL					
6	SPRING	STEEL WIRE	1	TEMPER	WITHIN : 1.5±0.1mm	SCALE: 2:1			
5	CONTACT CLIP	PBS STRIP	2	Ag PLATED	OVER : 1.5±0.2mm				
4	TERMINAL	BRASS STRIP	10	Ag PLATED OVER Ni PLATED		CHK'D FANGYING 2002-5-15			
3	BASE	PHENOLIC RESIN	1	NATURAL					
2	FRAME	STEEL STRIP	1	Ni PLATED		ALL MATERIALS MUST BE COMPLIANT TO ROHS			
1	KNOB	POM	1	BLACK					